



# San Jose DGPS Receiver

## MODEL: DGPS-216

An integrated GPS/Beacon receiver with built-in antennas that provides differential GPS corrections in NMEA-0183 format for navigation requiring high degree of accuracy



©2008 San Jose Technology, Inc. All specifications subject to change without notice.

### Overview

DGPS-216 is a combined high performance GPS receiver and a differential beacon receiver in an extremely compact and fully waterproof enclosure providing 1~5 meter DGPS positioning accuracy by utilizing the broadcasted (283.5~325KHz) GPS differential corrections from the USCG, CCG, or IALA Beacons at free of charge. Both GPS and Beacon receivers/ antennas are built inside the enclosure, making DGPS-216 a single device featuring easy installation, maintenance, and integrated services.

## Specification

<b>Antenna</b>	
GPS Antenna:	High-reliability ceramic patch
Beacon Antenna:	Ferrite loop antenna
GPS LNA gain:	17 +/- -2dB, NF: 2.0dB max
Beacon LNA gain:	34 +/- -2dB
<b>GPS RECEIVER</b>	
SIGNAL PROCESSING	
Receiver Frequency:	1575.42MHz, C/A code, L1 band
Receiver Architecture:	16-channel all-in-view algorithm tracks
Update Rate:	Standard: 1Hz (Optional: 1Hz~4Hz)
ACCURACY	
GPS Positioning Accuracy:	2.5m CEP, 5m SEP
DGPS Positioning Accuracy:	2m CEP, 3m SEP
TIME TO FIRST FIX	
Cold Start:	41 seconds
Warm Start:	33 seconds
Reacquisition:	1 seconds
<b>BEACON RECEIVER</b>	
SIGNAL PROCESSING	
Channel:	2-channel parallel tracking
Frequency Range:	283.5~325.0 kHz
Channel Spacing:	500 Hz
Minimum Signal Strength:	2.5 uV/m for 6dB SNR@200bps
Dynamic Range:	100 dB
Adjacent Channel Rejection:	61 dB ± 1 dB@ fo ± 400Hz
Acquisition Time:	< 2 sec., manual command
	< 2 sec., automatic warm start
	< 1 min., automatic cold start
Selection of Station:	Automatic or manual or database
DATA PROCESSING	
Demodulation:	MSK (Minimum Shift Keying)
MSK Bit Rates:	50, 100, 200 (automatic)
<b>GENERAL</b>	
DATA PORTS	
Monitor/Control Port:	RS-232 at 4800 baud
Control Format:	NMEA-0183 2.3 (Compatible to 3.0)
Housing:	7 pin circular, hermetically sealed
POWER REQUIREMENTS	
Input Voltage:	12~24V DC with power-reverse protection
Power Consumption:	Less than 3W @12 V DC (max.)
ENVIRONMENTAL	
Operating Temperature:	-30°C to +70°C
Storage Temperature:	-40°C to +80°C

©2010 San Jose Technology, Inc.  
All specifications subject to change without notice.

OEM OPTIONS	
Sentence Available:	GGA, GLL, GSA, GSV, VTG, RMC, ZDA
Output Interval:	0~60 sec. selectable
Type of Interface:	RS-232 (standard), RS-422 (optional)
Datum:	WGS-84 plus 170 user selectable datum
Extend Input Voltage:	Up to 60 VDC

Data Updated: Feb. 10, 2010

### Outline Drawing:

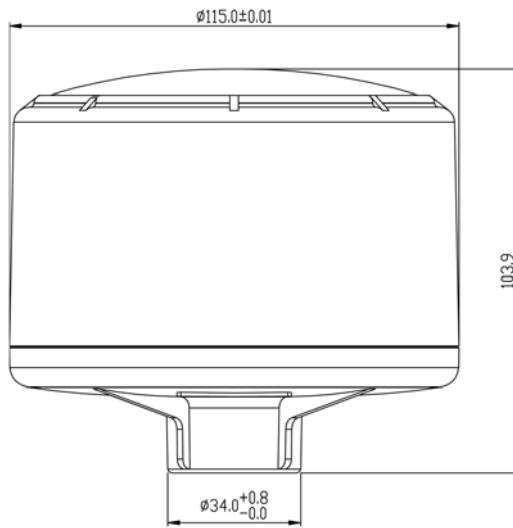

### System Configuration:

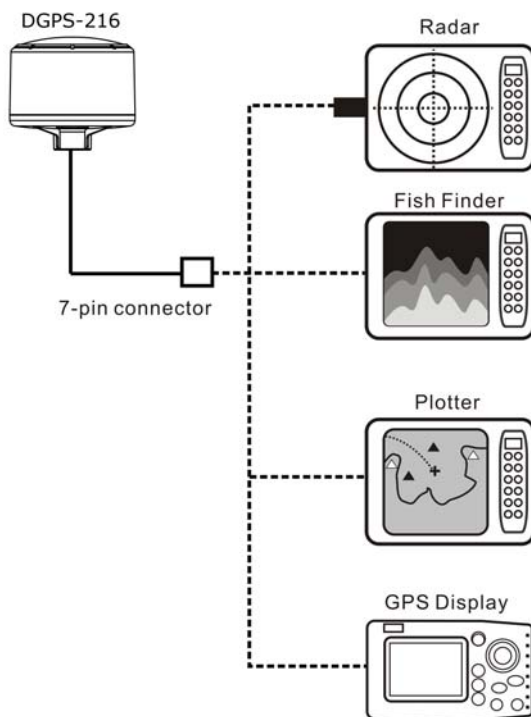

©2010 San Jose Technology, Inc.  
All specifications subject to change without notice.